

**HD 9817T1R, HD 9817T2R, HD 9817T3R, HD9817TVS
TEMPERATURE AND HUMIDITY TRANSMITTERS WITH ANALOG
OR DIGITAL OUTPUT RS232, USB OR RS485 MODBUS-RTU**

Dual relative humidity and temperature transmitter for HVAC applications, environmental monitoring, pharmaceutical storage, food transport, greenhouse automation, etc. Equipped with an IP65 stainless steel AISI 304 housing, it is suitable even for severe environments; besides, its ultra-compact dimensions (Ø 14 x 133 mm) and wide range of outputs (analogue 0...1V, digital RS232C OR RS485-MODBUS RTU, USB 1.1-2.0) make it ideal for integrating into a variety of OEM applications. It is supplied with the HD9817TC software for reading measurements and calibrating the relative humidity sensor.

VERSIONS, OUTPUTS AND CONNECTIONS

	HD9817T1R	HD9817T1R.1	HD9817T2R
Output	0...1V = 0...100%RH 0...1V = -40...+60°C		RS232C non insulated, 2400 baud rate
Temperature sensor	Pt100	NTC 10kΩ	Pt100
Load resistance	R _L > 10kΩ		
Cable Connection	L=1,5m (7 wires + shield)		L= 2m DB9 female connector

	HD9817T2R.B	HD9817T3R	HD9817TVS
Output	RS232C non insulated, 2400 baud rate	USB 1.1-2.0 non insulated	0...1V = 0...100%RH or 0...1V = -40...+60°C DP 0...1V = -40...+60°C RS485 Modbus RTU non insulated
Temperature sensor		Pt100	Pt100
Load resistance			R _L > 10kΩ
Cable Connection	L= 2, without connector	L= 2m USB connector type A	M12 8-pole connector. Provided with cable CP9817.3, L=3m

Connections

HD9817T1 and HD9817T1.1 models with 0...1Vdc analogue output.

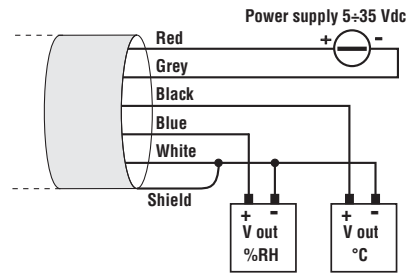

The instrument is equipped with a 7 wire + shield cable. The **Yellow** and **Green** wires are used during calibration only for PC connection through the HD9817T.1CAL interface module (see the paragraph about the RH sensor calibration).

Power is supplied to the **Red (+)** and **Grey (-)** wires.

The output signal voltage is taken from:

- **Black (+)** and **White (-)** wires for temperature,
 - **Blue (+)** and **White (-)** wires for relative humidity.
- The **shield** must be connected to the White wire.

HD9817T2 model with RS232C output and HD9817T3 model with USB output.

The HD9817T2 cable ends in a RS232C 9-pole subD female connector, while the HD9817T3 cable ends in a USB type A connector.

The following set of commands is available for both instruments.

Command	Response	Description
G0	HD9817T_Pt100_RH_RS232	Model
G3	Firm.Ver.=01-00	Firmware version
HAnn.n	&	75% calibration point where nn.n stands for the actual humidity value
HBnn.n	&	33% calibration point where nn.n stands for the actual humidity value
S0	0072.7 063.9	It sends the current measurement (tttt.t hhh.h) t = temperature h = RH
U0	&	International System of units
U1	&	Imperial units

Note for HD9817T3 model with USB output

This model requires that you install USB drivers first in order to ensure a correct PC connection: **don't connect the instrument to your PC before installing the drivers**. For further details, see the guide in the CDRom which is supplied with the instrument.

Wiring diagram of the 0...1Vdc analog outputs and of the RS485 digital output.

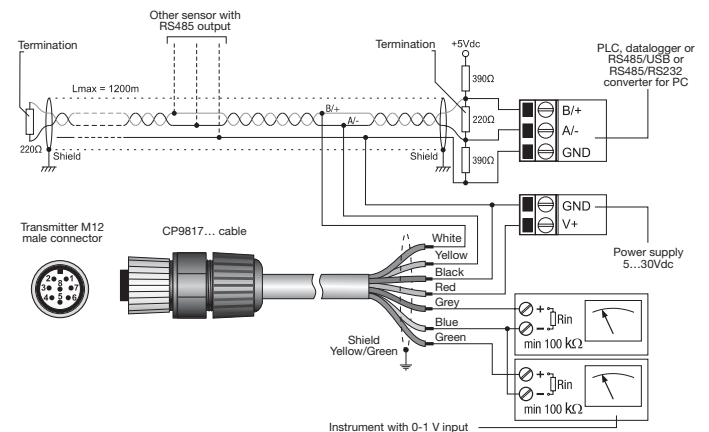

Setting parameters for RS485 communication

Before connecting the transmitter to the RS485 network you must assign an address and set the communication parameters if different those preset at the factory. The setting of the parameters is made by connecting the transmitter to the PC by using the cable **CP24** (optional) with integrated RS485/USB converter or the cable **CP9817.3** supplied with the instrument and a generic RS485/USB or RS485/RS232 converter.

RELATIVE HUMIDITY CALIBRATION

The instruments are supplied factory calibrated and ready to use. The CDRom supplied with the instruments includes a relative humidity calibration procedure. The online help describes this procedure in detail.

No procedure exists for temperature calibration.

To connect HD9817T1 and HD9817T1.1 models to your PC, use the HD9817T.1CAL interface module: the module is equipped with a USB type A connector for your PC USB port connection as well as a 4-pole terminal board to connect the transmitter.

Before connecting the module to your PC, you need to install the USB drivers: **don't connect the module to your PC before installing the drivers.** For further details, see the guide in the CDRom which is supplied with the instrument.

Please connect the **Red** (power supply positive), **Grey** (power supply negative), **Yellow** (Tx) and **Green** (Rx) wires as shown in the figure below.

The terminal board is seen from above: in order to direct the clamps correctly, make sure that the label on the side of the module is placed as shown in the figure below.

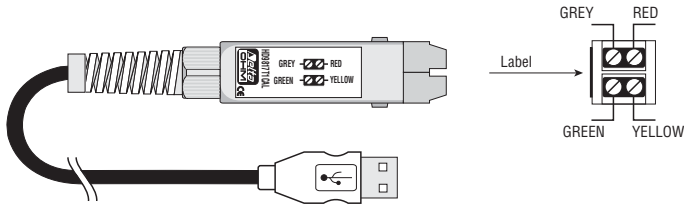

INSTALLATION NOTES

To fix the probe in a ventilation duct, pipe, etc. you can use, for example, the HD9008.31.12 flange, a PG16 metal cable gland ($\varnothing 10 \dots 14 \text{mm}$) or a 3/8" universal biconical connection.

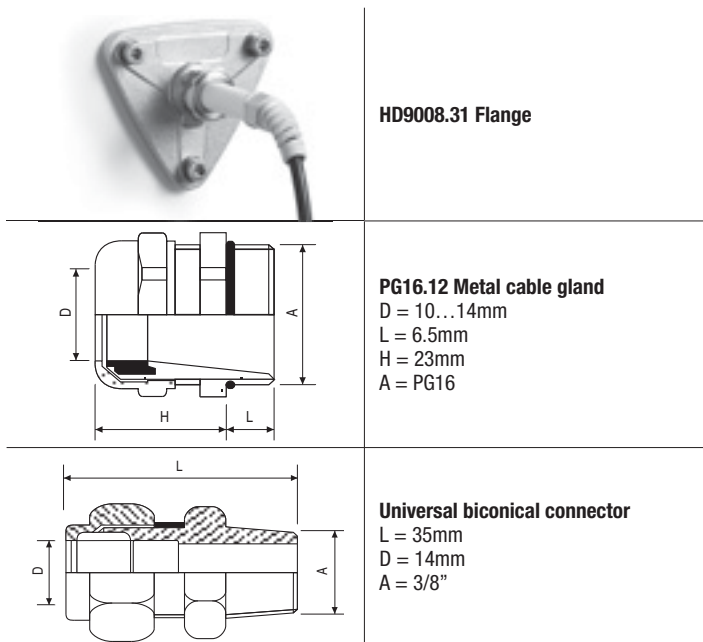

HD9008.31 Flange

PG16.12 Metal cable gland

D = 10...14mm
L = 6.5mm
H = 23mm
A = PG16

Universal biconical connector

L = 35mm
D = 14mm
A = 3/8"

For wall-mounted installation, the HD9008.21.1 (distance from wall 250mm) and HD9008.21.2 (distance from wall 125mm) supports are available. Both require the HD9008.26/14 adapter.

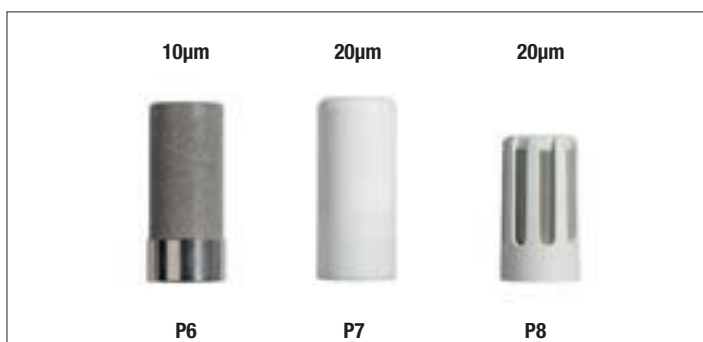

For direct wall mounting on a metal support, the HD9817T.4 part is available as shown in the figure below (for HD9817T1 and HD9817T1.1 versions only).

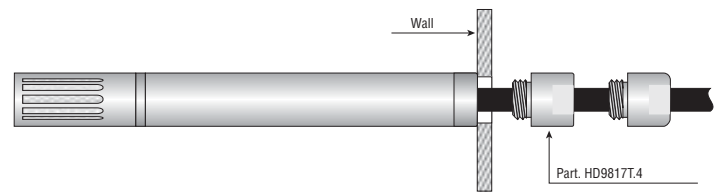

The wall can be 2mm thick at most while the hole in the wall can be 10.5mm.

Electrical connection

HD9817T1 and HD9817T1.1 models

Power supply

The power supply voltage must be as per the electrical specifications (5...35Vdc) between the wires:

Red = (+) power supply positive
Grey = (-) power supply negative.

Analogue output

The voltage output signals are taken from the following wires:

Blue = (+) %RH output positive
Black = (+) Temperature output positive
White = (-) ground. Common reference between %RH and Temperature outputs.
Shield = the braid is connected to the common ground (White wire).

HD9817T2 and HD9817T3 models

These models are powered directly from your PC port and no external power supply is required.

Models HD9817TVS with analog outputs 0...Vdc and RS485 MODBUS-RTU output. They are supplied with the cable CP9817.3 equipped with the M12 connector on the one side for the connection to the instrument and loose wires on the other side.

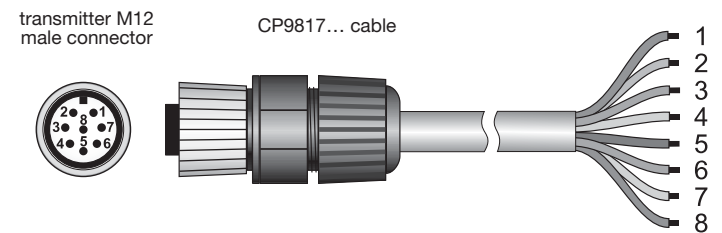

Connector	Function	Color
1	Power supply negative	Black
2	Power supply positive	Red
3	Not connected	
4	RS485 A/-	Yellow
5	RS485 B/+	White
6	Analog output negative	Blue
7	Temperature analog output positive	Grey
8	humidity analog output positive	Green
	Cable shield (not connected to the M12 connector)	Yellow/Green

HD9817T... DIMENSIONS

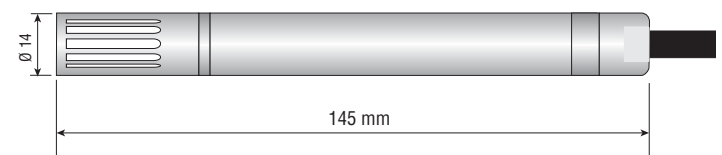

Environmental analysis

Technical data		
HD9817T1R - HD9817T1R.1 - HD9817T2R - HD9817T3R-HD9817TVS		
Relative humidity	Sensor	Capacitive
	Sensor protection	P8, stainless steel grid and PTFE, 20µ
	Measuring range	0...100%RH
	Sensor working range	-40...+80°C
	Accuracy @20°C	±1.5% (0...90%RH), ±2,0% in the remaining range
	Temperature dependence	2% on the whole temperature range
	Hysteresis and repeatability	0.4%RH
	Long term stability	1%/year
Temperature	Sensor type	Pt100 1/3 DIN (on request, NTC 10kΩ: code HD9817T1R.1)
	Measuring range	-40...+60°C
	Accuracy	±0.2°C ±0.15% of the measured value
	Long term stability	0.2°C/year
General	Power voltage	5...35Vdc
	Consumption	Typically 2mA
	Max. operating temperature	-40...+80°C (for short periods)
	Operating humidity	0...100%RH
Housing	Dimensions	Ø14x145mm
	Degree of protection	IP65

ORDER CODES

HD9817T1R: Dual relative humidity and temperature transmitter, Pt100 sensor. 0...1Vdc analogue outputs. Temperature measuring range -40...+60°C (-20...+80°C on request). Power supply 5...35Vdc. AISI 304 housing. Probe protection class IP65. Dimensions Ø14x145mm. Output with cable L=1,5m (7 wires + shield). Max. working temperature -40...+80°C. **Supplied with HD9817TC software.**

HD9817T1R.1: Dual relative humidity and temperature transmitter, NTC sensor 10kΩ. 0...1Vdc analogue outputs. Temperature measuring range -40...+60°C (-20...+80°C on request). Power supply 5...35Vdc. AISI 304 housing. Probe protection class IP65. Dimensions Ø14x145mm. Output with cable L=1,5m (7 wires + shield). Max. working temperature -40...+80°C. **Supplied with HD9817TC software.**

HD9817T2R: Dual relative humidity and temperature transmitter, Pt100 sensor. RS232C digital output. Temperature measuring range -40...+60°C (-20...+80°C on request). Powered directly from your PC RS232C port. AISI 304 housing. Probe protection class IP65. Dimensions Ø14x145mm. Output with cable L= 2m with DB9 female connector. Max. working temperature -40...+80°C. **Supplied with HD9817TC software.**

HD9817T3R: Dual relative humidity and temperature transmitter, Pt100 sensor. USB1.1-2.0 digital output. Temperature measuring range -40...+60°C (-20...+80°C on request). Powered directly from your PC USB port. AISI 304 housing. Probe protection class IP65. Dimensions Ø14x133mm. Output with cable L= 2m with USB type A connector. Max. working temperature -40...+80°C. **Supplied with HD9817TC software.**

HD 9817T2 - RS232 SERIAL CONNECTIONS

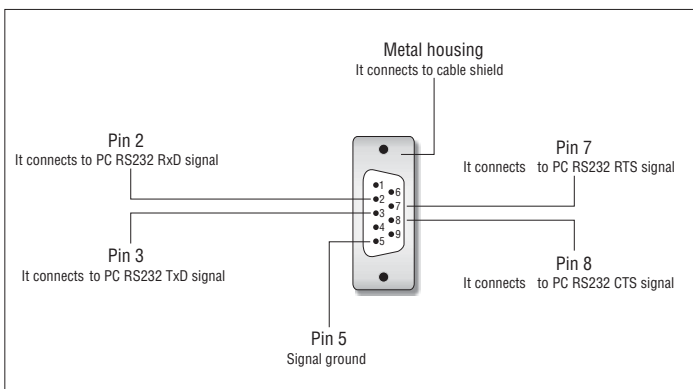

HD9817TVS: Dual relative humidity and temperature transmitter, Pt100 sensor. 0...1Vdc analogue and RS485 MODBUS-RTU output. Temperature measuring range - 40...+60°C. Power supply 5...35Vdc. AISI 304 housing. Probe protection class IP65. Dimensions Ø14x145mm. Output with cable M12 8-pole connector. **Supplied with CP9817.3 cable, length 3m.**

CP24: PC connecting cable for the MODBUS parameters configuration. With built-in RS485/USB converter. 8-pole M12 connector on instrument side and A-type USB connector on PC side.

CP9817.3: Spare cable for HD9817TVS transmitter, with 8-pole M12 female connector on one side, open wires on the other side. Length 3 m.

HD9817T.4: Wall-mounting adapter. Only for HD9817T1 and HD9817T1.1 on request.

HD9817T1CAL: USB interface module for connecting HD9817T1 and HD9817T1.1 transmitters to your PC USB port as well as calibrating or checking the humidity sensor. USB connector type A, cable L=1.5m. Connection through 4-pole terminal board.

HD75: saturated salt solution 75% R.H. thread M 12x1.

HD33: saturated salt solution 33% R.H. thread M 12x1.

HD9008.21.1: holder for vertical sensor, wall distance 250mm, hole Ø 26. HD9008.26.14 adapter is required.

HD9008.21.2: holder for vertical sensor, wall distance 125mm, hole Ø 26. HD9008.26.14 adapter is required.

HD9008.26/14: holders for Ø 26 and Ø 14mm holes, for HD9008.21.1 and HD9008.21.2

HD9008.31: flange with sensor block Ø 14mm for duct sensors TC and TO series.

HD9007 A-1: 12 ring protection from solar radiations for Ø 26mm probes. Complete with mounting brackets. For the transmitters HD9817T the HD9007T26.2 adapter can be provided.

HD9007 A-2: 16 ring protection from solar radiations for Ø 26mm probes. Complete with mounting brackets. For the transmitters HD9817T the HD9007T26.2 adapter can be provided.

HD9007T26.2: fitting for Ø 14mm transmitters (HD9817T...) for the protections from solar radiations HD9007 A-1 and HD9007 A-2.

P6: 10µ sintered stainless steel protection for probes Ø 14mm, thread M 12x1.

P7: 20µ PTFE protection for probes Ø 14mm, thread M 12x1.

P8: 20µ stainless steel and Poca grid protection, thread M 12x1.

